

Squirrel SQ2040

Powerful data loggers for all applications

Grant
DATA ACQUISITION

Overview

The Squirrel 2040 series combines a higher channel count with the same high performance, comprehensive features and universal inputs as the 2040 in a neat compact and portable instrument.

Using multiple 24-bit analogue to digital convertors, twin processors and removable memory options provides great flexibility to handle a wide range of complex and demanding multi-channel applications. The Squirrel 2040 series are the ideal data loggers for industrial, scientific research and quality assurance applications. The 2040 provides standalone data acquisition, advanced networked solutions and data analysis straight out-of-the-box.



**3 Year
Warranty**

Key features

- 16 true differential or 32 single ended universal analogue inputs for voltage, current or resistance measurements plus 2 high voltages, 4 pulse and 8 digital event/state inputs
- Analogue inputs can be used with thermistors, thermocouples, 2,3 or 4 wire RTD temperature sensors and 4 – 20mA signals
- User selectable logging rates of up to 100Hz on up to 4 channels
- Download of internal data to removable MMC/SD (Multi Media Card / Secure Digital) memory
- Large non-volatile internal memory – data retention is virtually indefinite
- Ethernet, USB and RS232 communication ports
- Sensor power and FET outputs for use with external devices
- Comprehensive access to information using the 2 line, 20 character LCD and button panel
- Calculated channels derived from real channels using advanced mathematical functions e.g. $\log(x)$; $\ln(x)$; \sqrt{x}

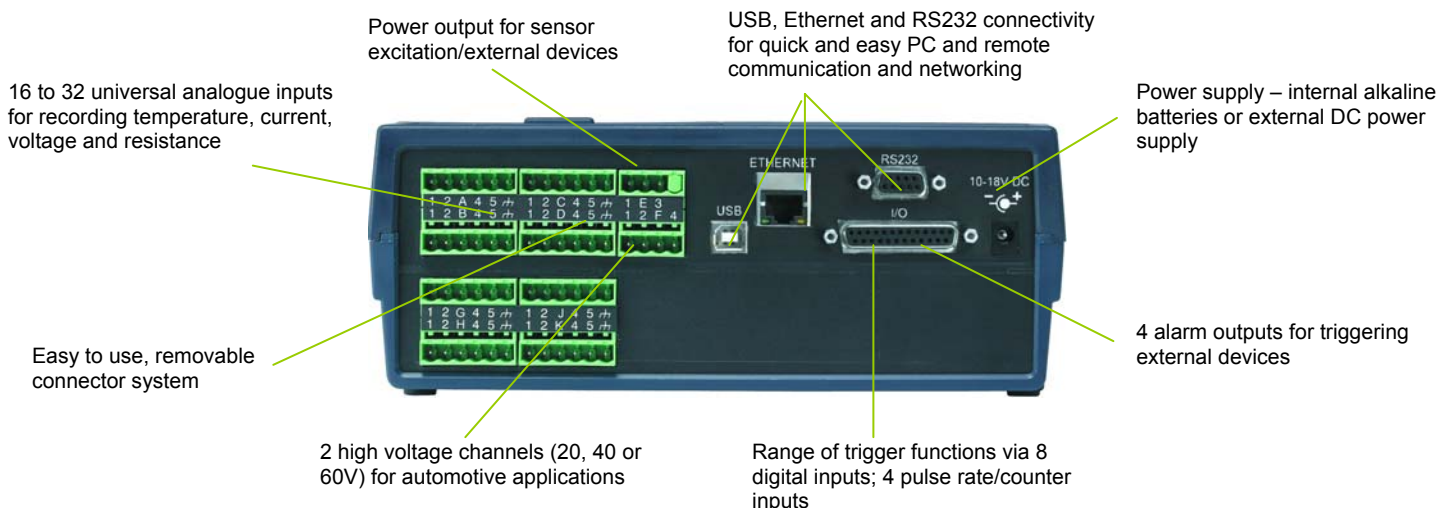

Communications:

Ethernet, USB and RS232 serial ports are inbuilt. This allows quick connection to either a PC based TCP/IP network, a wireless to PC connection or to a modem for remote data downloading. This flexibility enables global data access and retrieval as well as complete system integration of the SQ2040 series into complex and critical applications.

Multiple configurations stored in the logger:

Up to six logger configurations (channel type, names, logging speeds, triggers etc), together with the current configuration, can be held in the logger's internal memory. Additional configuration settings can also be loaded from the external MMC/SD memory card. This allows the operator to quickly and easily switch between logger configurations without the need for a PC.

Comprehensive software configuration via SquirrelView:

The SquirrelView software (supplied with the SQ2040 series data loggers) allows logger configuration, data download and data export whilst giving the user full control over the SQ2040. The optional SquirrelView Plus gives the user access to many advanced data analysis and data archiving/transfer features. Please refer to our separate SquirrelView data sheet for all its advanced features.

Concurrent sampling:

The SQ2040 series uses multiple analogue to digital converters that enables true concurrent sampling and logging. This allows the user to configure up to 4 channels to log at a rate of 100Hz whilst retaining different sample speeds on other channels. This makes the SQ2040 series ideal for measuring dynamic parameters that change at different rates such as temperature and pressure.

System specifications:

Input channels:

		SQ2040 - 2F16	SQ2040 - 4F16
Analogue input channel options	Analogue to digital converters	2	4
	Differential	16	16
	Single ended*	32	32
	3 or 4 wire	0	8
Additional channels	Pulse	(2 x fast – 64kHz) & (2 x slow – 100Hz)	(2 x fast – 64kHz) & (2 x slow – 100Hz)
	Event/digital	8 state inputs or 1 x 8 bit binary	8 state inputs or 1 x 8 bit binary
	High voltage	2	2
	Internal channels	2 temperature	2 temperature
	Logging speeds*	1 sec to 1 day in 1 sec increments 2, 5, 10, 20 or 100Hz (20Hz or 100Hz only on 2 channels)	1 sec to 1 day in 1 sec increments 2, 5, 10, 20 or 100Hz (20Hz or 100 Hz only on 4 channels)

*Please refer to our Technical Note for the configuration of these inputs

Standard ranges for temperature channels:

Each channel can be individually set to any of the ranges listed below. Pt100 to IEC751 and JIS1604 and Pt1000 to IEC751.

Input type	Ranges °C	Ranges °F
Y & U: Thermistor	-50 to 150	-58 to 302
Pt100/Pt1000*	-200 - 850	-328 to 1562

*2 wire only on 2F16 - 3 or 4 wire on 4F16

Input type	Ranges °C	Ranges °F
K: Thermocouple	-200 to 1372	-328 to 2501
T: Thermocouple	-200 to 400	-328 to 752
J: Thermocouple	-200 to 1200	-328 to 2192
N: Thermocouple	-200 to 1300	-328 to 2372
R & S: Thermocouple	-50 to 1768	-58 to 3214

Standard ranges for d.c. voltage:

Each voltage channel can be any of the voltage ranges below. Mixed differential and single ended configurations are permitted. Please refer to our Technical Note for the permitted combinations of inputs

Voltage range	Voltage range	High voltage input ranges*
-0.075 to 0.075V	-3.0 to 3.0V	4.0 to 20.0V
-0.15 to 0.15V	-6.0 to 6.0V	4.0 to 40.0V
-0.3 to 0.3V	- 6.0 to 12.0V	4.0 to 60.0V
-0.6 to 0.6V	-6.0 to 25.0V	
-0.6 to 1.2V		
-0.6 to 2.4V		

*Max of 2 may be selected

Standard ranges for current and resistance channels:

Each current channel can be any of the current ranges below. Current ranges use differential input channels.

Current range (External 10Ω shunt)	Resistance range 2 wire	Resistance range 3 and 4 wire (4F16 version)
-30.0 to 30.0mA	0.0 to 1250.0Ω	0.0 to 500.0Ω
4 to 20mA	0.0 to 5000.0Ω	0.0 to 4000.0Ω
	0.0 to 20000.0Ω	
	0.0 to 300000.0Ω	

Analogue inputs

Accuracy: (at 25°C) voltage and resistance
± (0.05% readings + 0.025% range)
Common mode rejection: 100dB
Input impedance: > 1M Ω
Linearity: 0.015%
Series mode line rejection: 50/60Hz
100dB

Analogue – digital conversion

Type: Sigma -Delta
Resolution: 24bit
Sampling rate: up to 10, 20* or 100*
readings per second per ADC.

* With mains rejection off

Alarm outputs

4 x open drain FET (18V 0.1A)

Power output for external device

Regulated 5 VDC at 50mA or
logger supply voltage at 100mA

Time and date

In-built clock in 3 formats

Scaling data

Displays readings in preferred
engineering units

Memory

Internal: 16Mb (Up to 1,800,000
readings)
External: Up to 1Gb - removable
MMC/SD (For transferring internal
memory and storing setups only)

Calculated channels

Up to 16 virtual channels derived
from physical input channels

Resolution

Up to 6 significant digits

Programming/logger setup

SquirrelView or SquirrelView Plus
software

Communication

Standard: RS232 (Auto bauding to
115200 baud)
Ethernet 10/100 base TCP/IP
USB 1.1 and 2.0 compatible
External options: GSM, WIFI and
PSTN Modems

Power supply

Internal: 6 x AA Alkaline batteries
External: 10-18VDC
Reverse polarity and over-voltage
protected

Power consumption @ 9V

Sleep mode: 600µA
Logging: 40-130mA

Dimensions and weight

Dimensions: W235 x D175 x
H95mm
Weight: Approx 1.2kgs
Enclosure material: ABS

Memory modes (internal only)

Stop when full or overwrite

Display and keypad

2 line x 20 character LCD display
Battery state and external power
indicator
Keypad lock
Navigate to:
Arm/disarm/pause/continue
Meter any channel or alarm
Select from up to 6 x pre-stored
setups
Status/diagnostics/memory/time
and date
Download to MMC/SD

Operating environment

-30°C to +65°C
Humidity: 90% at 40°C non-
condensing

Accessories

MPU 12V: Universal (97-263V
AC) power supply
LC76: DC lead
SQ20RB12-6: External
rechargeable battery (12V, 6Ah)
SB102: 25 way digital I/O
connector
CS202: Current shunt kit (4 x 10Ω
0.125W)
PEL4: Rugged weather proof
enclosure
CAL2040: Test and Calibration
certificates
SQ20A802: External GSM
communications kit
MMC64: Multi Media Card
(Please see price list for additional
accessories)

Please note: SQ2040 is supplied
with software, manual, USB
cable, wall bracket and batteries
and 4 current shunt resistors.

Grant

Grant Instruments (Cambridge) Ltd
Shepreth, Cambridgeshire SG8 6GB
England

Tel: +44 (0) 1763 260 811
Fax: +44 (0) 1763 262 410
Email: acquisitionsales@grant.co.uk

www.grant.co.uk

Grant data loggers and specialist technical support is available world-wide. Please visit www.grant.co.uk to locate our regional offices and to download technical support materials. You will also find your locally appointed distributor and support centre.

Grant data logging systems bear a CE mark and meet relevant European directives.

Grant Instruments operates a Quality Management System complying with ISO9001:2000. It is Grant's policy to supply customers with products which are fit for their intended purpose, safe in use, perform reliably to published specification and are backed by a fast and efficient customer service.

All specifications are subject to continuous development and Grant Instruments (Cambridge) Ltd reserves the right to alter them without prior notice.

All trademarks acknowledged.